

# CARGO Sky®

HIGH PERFORMANCE CASTERS



Rua Álvaro do Vale, 284 - São Paulo - SP - BRAZIL - ZIP CODE: 04217-010 - Phone/Fax: (55 11) 6165-5200  
[www.schioppa.com.br](http://www.schioppa.com.br)

CMY&K Comunicação • Setembro 2002

# CARGO Sky®

HIGH PERFORMANCE CASTERS



# HIGH PERFORMANCE CARGO LINE

**CARGO** Sky



**Cargo Sky® Line is designed for handling and transporting loads under both extreme environmental conditions, and lighter applications.**



**Cargo Sky® with Thread Guard**

**Cargo Sky®**

## Fastening Types

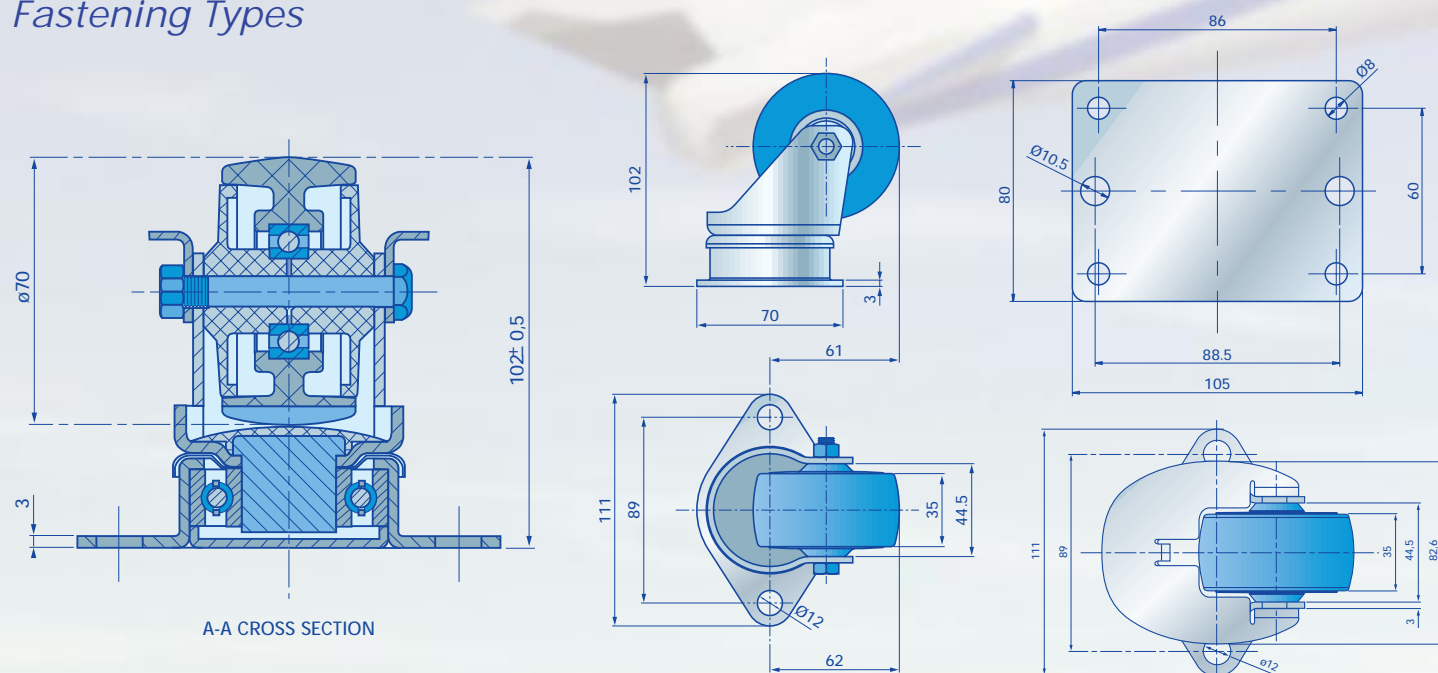

## Bearings

Cargo Sky® casters special design and building keep the ball bearings permanently sealed even if casters are seriously damaged, thus preventing more damages and losses.

## Wheels

Made of nylon, they are present in all Cargo Sky® Line casters, due to their high durability and shock-resistance, which increases their service life. Load handling is made easy to the maximum through precision ball bearings present in all wheels.

## Top plate and forked leg

Submitted to rigid and tested construction standards, they are made of high quality steel with 3mm (1/8") thickness in our plant in São Paulo, SP, Brazil, under very strict tolerances in order to ensure consistency during the whole manufacturing process. Casters are bichromated for protection against rust and corrosion.

## Durability tests

Cargo Sky® Line has a proven service life 80% higher than the similar products available in the market.

## Applications:

- Modular containers loading and unloading
- Aircraft/Spacecraft industry
- Extra heavy load moving
- Textile industry
- Logistics/Carriers

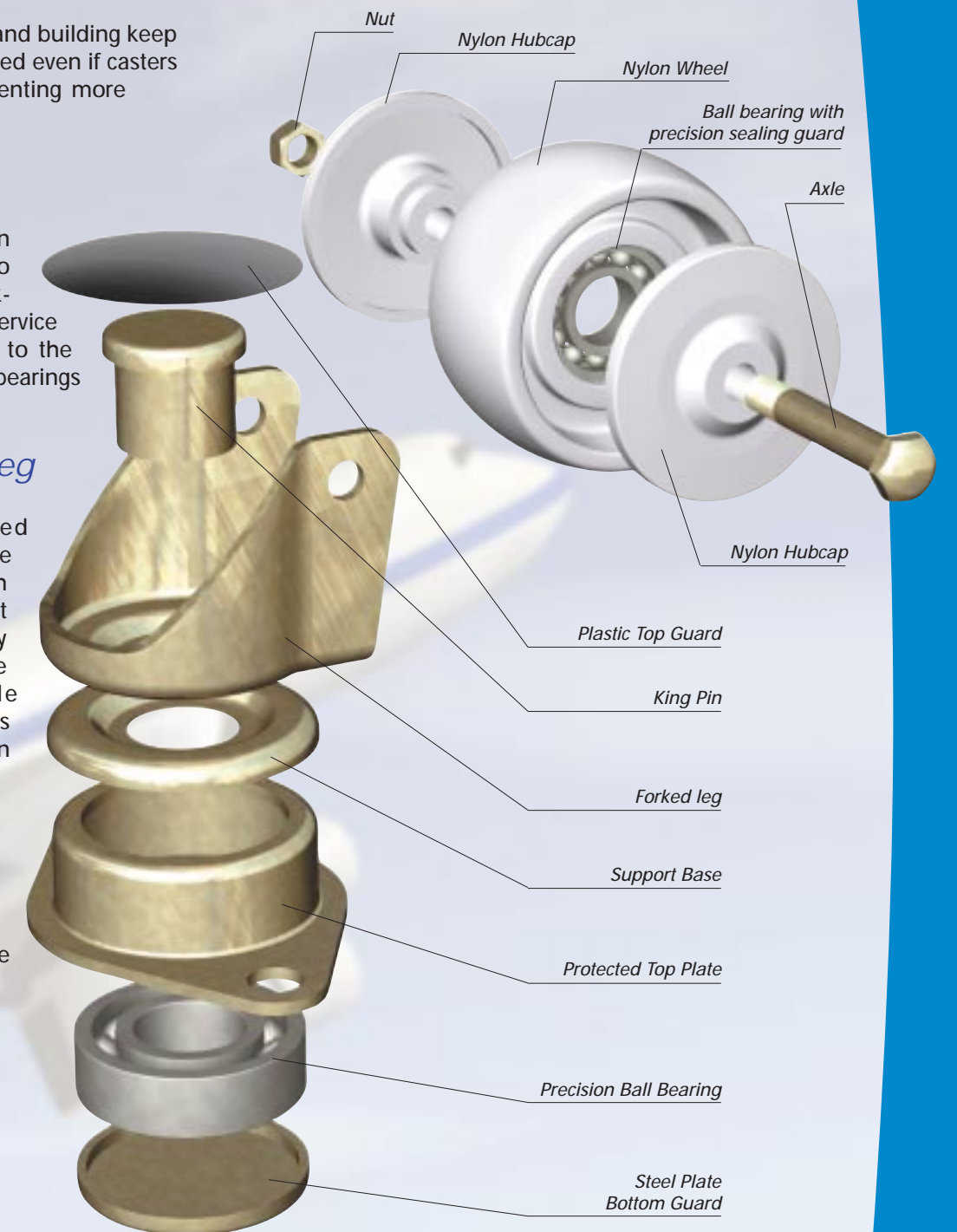

WHEEL	WHEEL WIDTH	HOLE DIAMETER	HUB WIDTH	HEIGHT	SWIVEL RADIUS	LOAD CAPACITY	MATERIAL	REFERENCE
57	35	8	44.5	96	61	250 KG	NYLON	GLUP 214 NTE
70	35	8	44.5	102	61	250 KG	NYLON	GLUP 314 NTE