

Load capacity up to 80 kg.

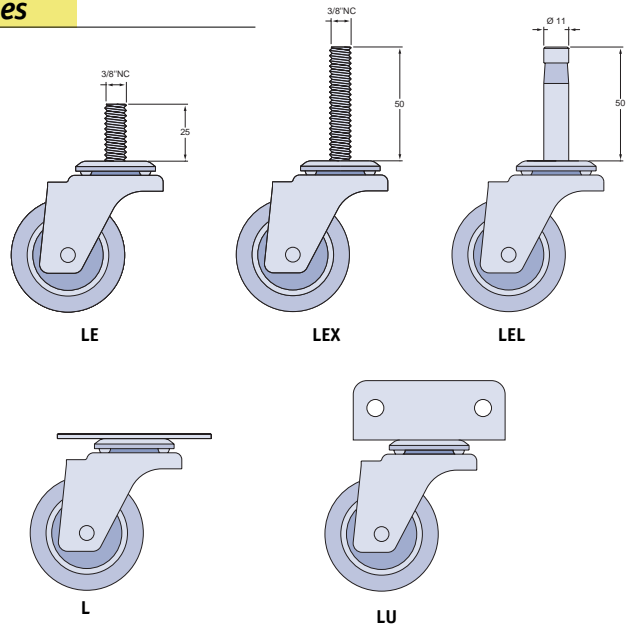

Fastening Types



Wheels

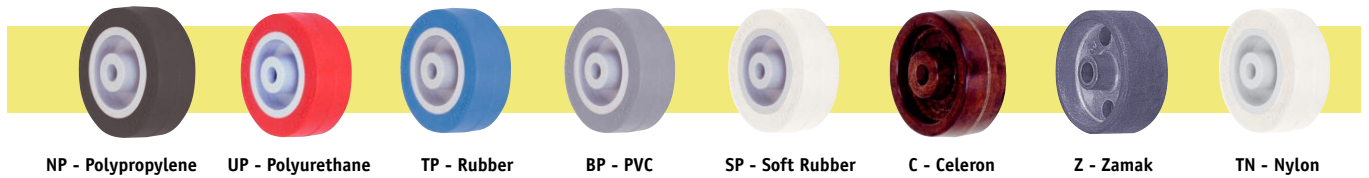

NP - Polypropylene    UP - Polyurethane    TP - Rubber    BP - PVC    SP - Soft Rubber    C - Celeron    Z - Zamak    TN - Nylon

Accessories

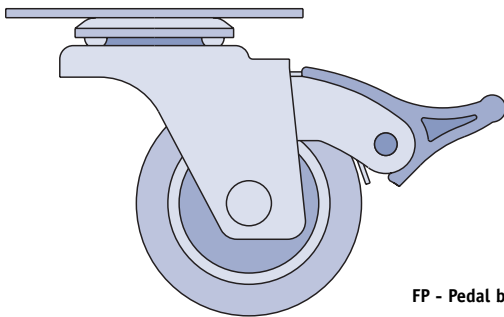

FP - Pedal brake

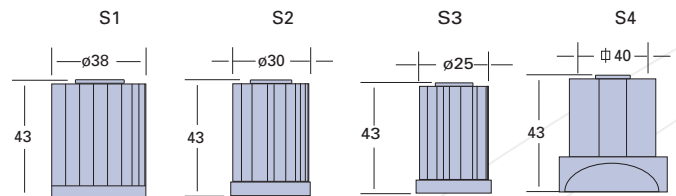

S - Grip ring stem bushing

Flange Fastening

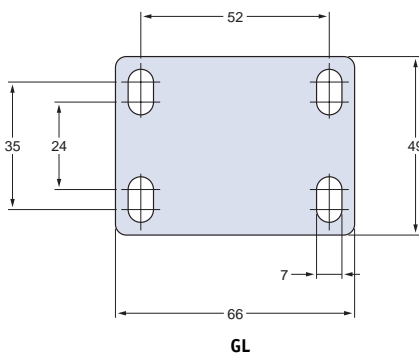



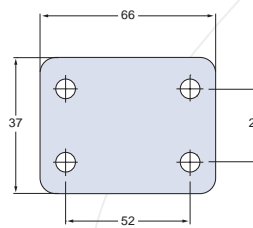

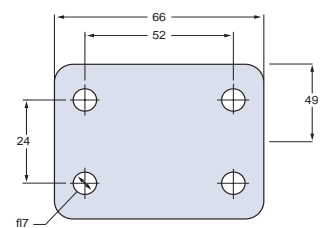
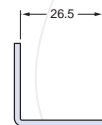

GL

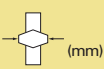
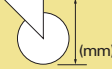

FL



							Ref. Wheel	Ref. Caster with Top Plate	
									
1.5/8"	3/4"	1/4"	20	57	41	55	R 158 Z	GL 158 Z	FL 158 Z
						25	R 158 NT	GL 158 NT	FL 158 NT
2"	3/4"	1/4"	25	67	45	30	R 210 BP	GL 210 BP	FL 210 BP
						45	R 210 NP	GL 210 NP	FL 210 NP
						40	R 210 TP	GL 210 TP	FL 210 TP
						45	R 210 UP	GL 210 UP	FL 210 UP
						40	R 210 SP	GL 210 SP	FL 210 SP
						45	R 210 NT	GL 210 NT	FL 210 NT
						50	R 210 C	GL 210 C	FL 210 C
						80	R 210 Z	GL 210 Z	FL 210 Z
3"	3/4"	1/4"	25	92	65	35	R 310 BP	GL 310 BP	FL 310 BP
						50	R 310 NP	GL 310 NP	FL 310 NP
						45	R 310 TP	GL 310 TP	FL 310 TP
						50	R 310 UP	GL 310 UP	FL 310 UP
						45	R 310 SP	GL 310 SP	FL 310 SP
						50	R 310 NT	GL 310 NT	FL 310 NT
4"	3/4"	1/4"	25	122	89	65	R 410 BP	GL 410 BP	
						80	R 410 NP	GL 410 NP	
						75	R 410 TP	GL 410 TP	
						80	R 410 UP	GL 410 UP	
						75	R 410 SP	GL 410 SP	
						80	R 410 NT	GL 410 NT	

All dimensions in mm